

Assembly Instructions

2-Piece & 4-Piece Conversion Kits

Part Numbers:

1927-3-002-00

1927-3-004-00

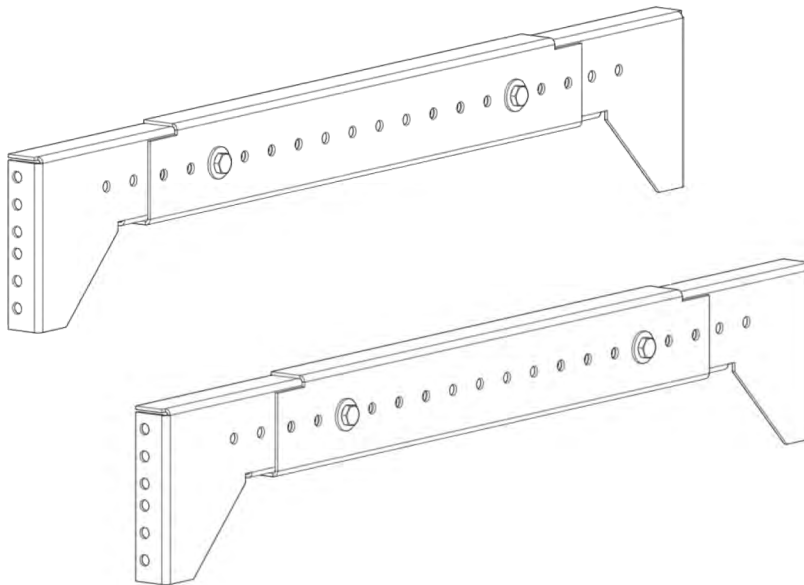

CablesPlus
U ★ S ★ A

DISTRIBUTED BY: Cables Plus, LLC | 5608 West Marshall St, Richmond, VA 23230
Toll Free: (866) 678-5852 | Fax: (804) 716-9040 | www.cablesplususa.com

Tools needed:

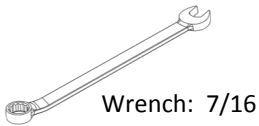

Wrench: 7/16



Phillips Head
Screwdriver

What's in the box:

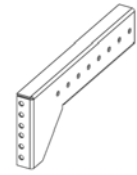

QTY 4 (4-Piece)
QTY 2 (2-Piece)
Left Arm Brackets

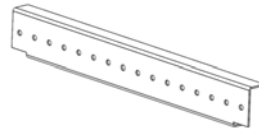

QTY 4 (4-Piece)
QTY 2 (2-Piece)
Center Arm Brackets

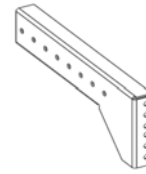

QTY 4 (4-Piece)
QTY 2 (2-Piece)
Arm Brackets



QTY 16 (2-Piece) 32 (4-Piece)
Flat Washers



QTY 8 (2-Piece) 16 (4-Piece)
7/16 Hex Nuts



QTY 8 (2-Piece) 16 (4-Piece)
7/16 Hex Bolts

Step 1:

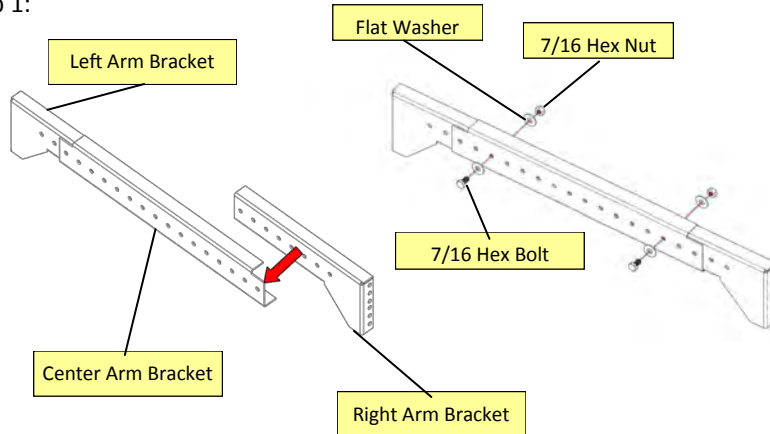

Insert the Left and Right Arm Brackets into the Center Arm Bracket as shown and secure with included 7/16 hardware. Make sure you set them for your desired depth. Follow this step for each of the arm assemblies.

* Note - Be sure the Center Arm is centered so the weight is evenly distributed.

Step 2:

Mount one arm at a time to each rack using the correct screws for your rack type (not included), placing them at the upper corners (2-Piece Conversion Kit) or upper and lower corners (4-Piece Conversion Kit). The more screws that you use to mount the arms to your 2-post racks, the stronger the overall rack will be. Each arm allows for six screws per side.

Wall Mount Installation: For wall mount application, install the arms as shown to the right and attach the opposite end to the wall. We recommend using a piece of plywood or similar material to attach the arms too. Then attach the plywood to the wall using anchor bolts directly into the wall studs.

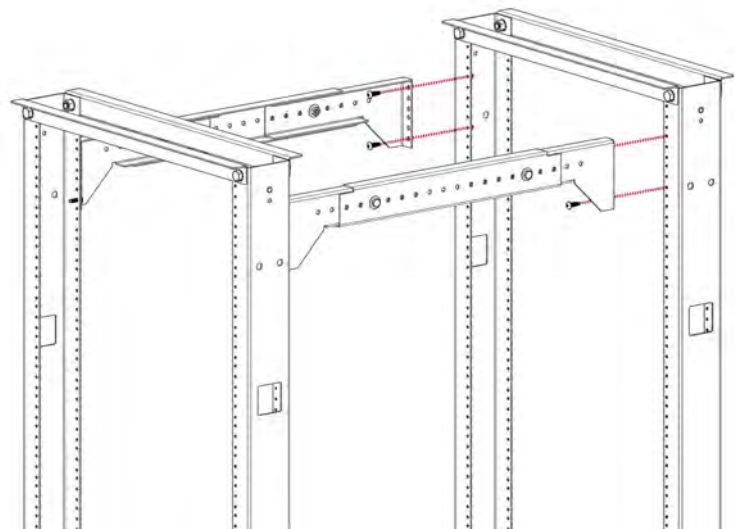

For details about product warranty, please visit www.kendallhoward.com

DISCLAIMER: Kendall Howard LLC. endeavors to make this manual accurate and complete. However, Kendall Howard LLC makes no representations or warranties of any kind, expressed or implied, about whether the use of products contained herein would infringe any rights or the correctness, accuracy or reliability of the information contained herein or that said information covers all details, conditions or variations. The information herein does not provide for every possible contingency in connection with the installation or use of the product(s). The information contained in this document is subject to change without notice or obligation. Kendall Howard LLC assumes no responsibility for the accuracy, completeness or reliability of the information contained in this document. Any reliance placed on the information is therefore strictly at your own risk.