

# 3.00" Double Vertical Cable Management Ring

## PRODUCT SPECIFICATION

### Package includes:

- A. 3.00" Double Vertical Cable Management Ring, 1 pc
- B. #12-24 x 5/8" Pan Head, Pilot Point Machine Screw, 4 pcs

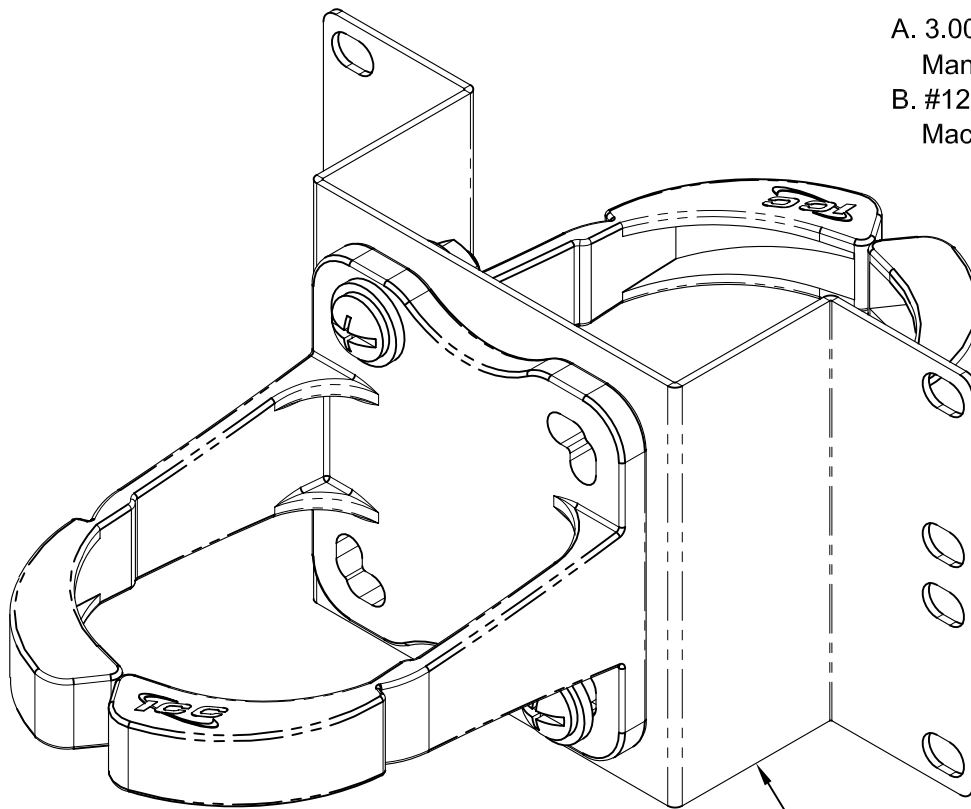

3.00" Double Vertical Cable Management Ring

### Features and Benefits:

- Provides flexibility for front and back cable management with a neat and clean appearance
- Suitable for all racks, wall mount racks, and wall mount brackets
- Fits on the sides of individual racks/brackets but can also be used to join two distribution racks
- Used with ICCMS distribution racks and ICCMSWMR wall mount racks

### RING, VERTICAL CABLE MGMT, DOUBLE, 3.00"

|          |            |          |   |   |
|----------|------------|----------|---|---|
| ITEM NO. | ICCMSCMPR8 | REV.     | A | <br><i>PremiumProducts</i><br><i>ProvenPerformance</i><br><i>CompetitivePrices</i> |
| DWG NO.  | PSCMSCMPR8 | PAGE NO. | 1 |   |

Available from:

Available from:

# CablesPlus

U ★ S ★ A

Cables Plus, LLC

8504 Glazebrook Ave Richmond, VA 23228 ~ Toll Free (866) 678-5852

www.CablesPlusUSA.com

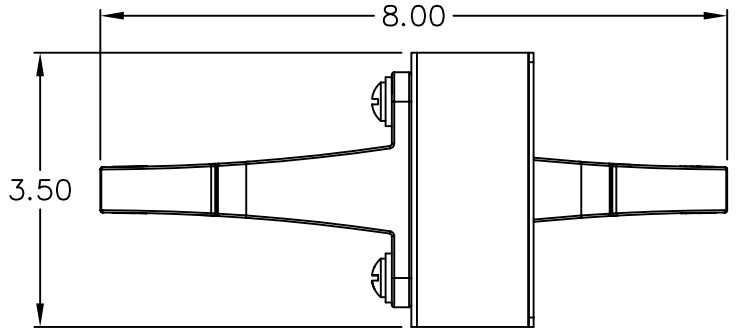
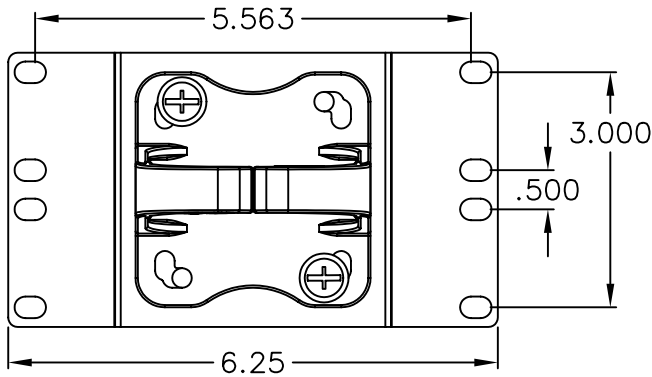
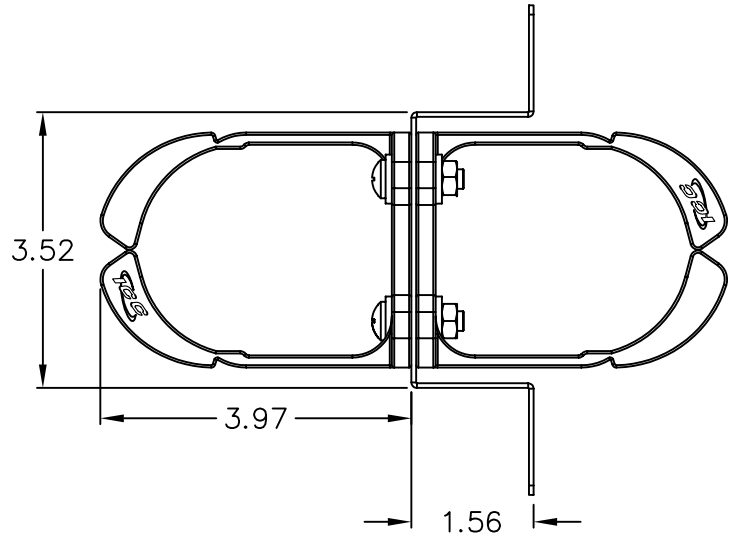

**NOTE: UNLESS OTHERWISE SPECIFIED**

1. RING:

- A. MATERIAL: HIGH IMPACT ABS, UL 94V-0
- B. COLOR: BLACK

2. BRACKET:

- A. MATERIAL: 16 GA CRS
- B. SURFACE FINISH: BLACK POWDER COAT

**RING, VERTICAL CABLE MGMT, DOUBLE, 3.00"**

|          |            |
|----------|------------|
| ITEM NO. | ICCMSCMPR8 |
| DWG NO.  | PSCMSCMPR8 |

|          |   |
|----------|---|
| REV.     | A |
| PAGE NO. | 2 |



# CablesPlus

U ★ S ★ A

<http://www.cablesplususa.com/>

☎ 866-678-5852