

# 12-Port Category 6 Vertical Patch Panel

## PRODUCT SPECIFICATION

### Package includes:

- A. 12-Port CAT 6 Vertical Patch Panel, 1 pc
- B. Termination Cap, 24 pcs
- C. 89U Universal Mounting Bracket, 1 pc
- D. 6" Cable Tie, 3 pcs
- E. Installation Instructions, 1 sheet

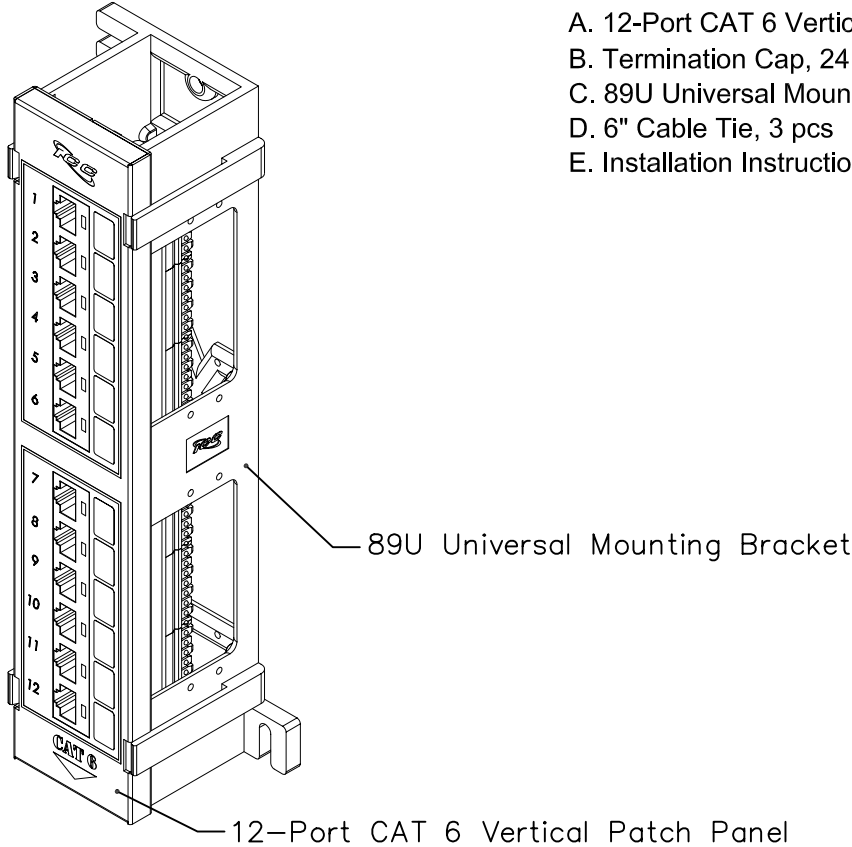

### Features and Benefits:

- Wall mounted CAT 6 component rated patch panel provides excellent performance for data networks requiring maximum speed and bandwidth
- Enhanced crosstalk cancellation reduces return loss and improves performance by rejecting noise and unwanted signals
- Exceeds ANSI/TIA/EIA-568-B.2-1 Category 6 connecting hardware requirements
- Engineered to provide 110 IDC termination reducing installation time
- Includes an integrated TIA-568A/B color wiring diagram
- Backwards compatible to all lower rated category components
- Used with ICPCS6 CAT 6 patch cords and ICACSPDT00 110 punch down tool
- Installation instructions #MSR-0293 included
- UL listed

<b>PATCH PANEL, VERTICAL, CAT 6, 12-PORT</b>		 Premium Products Proven Performance Competitive Prices	
ITEM NO.	ICMPP12V60		REV. B
DWG NO.	PSMPP12V60		PAGE NO. 1

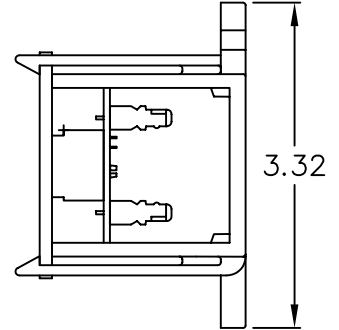
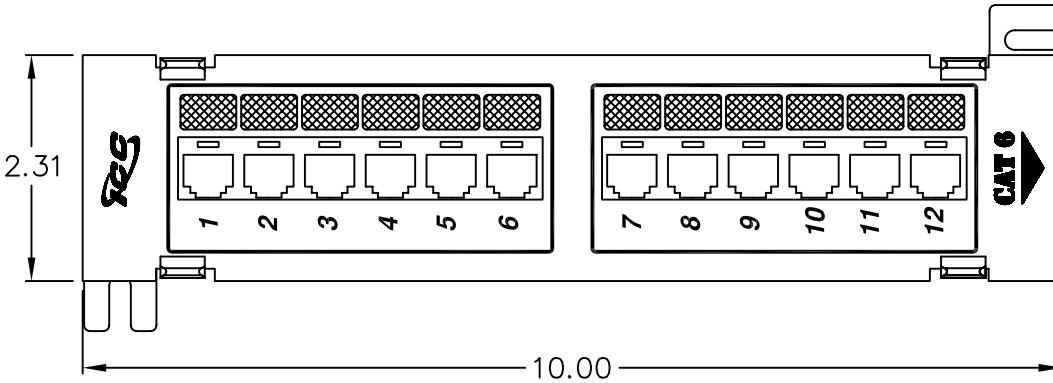
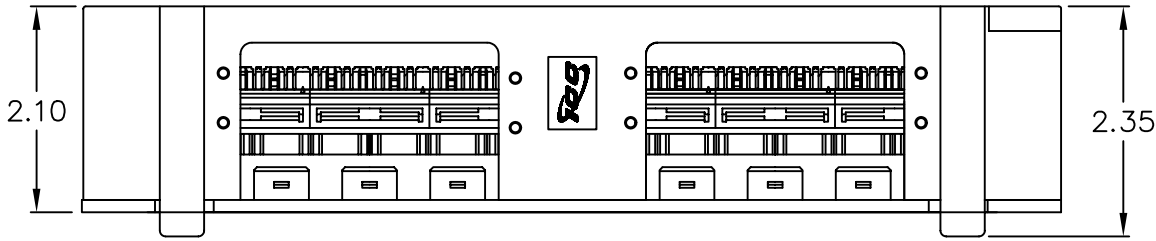

**NOTE: UNLESS OTHERWISE SPECIFIED**

1. 12-PORT CAT 6 VERTICAL PATCH PANEL:

A. MATERIAL:

- 12-PORT VERTICAL PATCH PANEL: ALUMINUM, 1.25" THICK
- JACK HOUSING: ABS, UL 94V-0
- SPRING WIRE: SQUARE SPRING WIRE, TEMPERED PHOSPHOR BRONZE
- 110 CONNECTOR: COPPER ALLOY, 100 MICRO INCHES OF BRIGHT SOLDER  
OVER 100 MICRO INCHES OF NICKEL UNDERPLATE
- GOLD RATING: 50 MICRO INCHES OF GOLD OVER 100 MICRO INCHES OF NICKEL

B. SURFACE FINISH: BLACK POWDER COAT

C. MECHANICAL:

- MATING FORCE: 100 GRAMS MIN/CONTACT  
TEMPERATURE RANGE: -40°~150°F (-40°~66°C)
- PLUG RETENTION IN JACK: 30 LBS (133N) MIN

D. ELECTRICAL:

- CURRENT RATING: 1.5 AMP DC
- CONTACT RESISTANCE: 5 MILOHMS

2. TERMINATION CAP:

- A. MATERIAL: PC, UL 94V-0
- B. COLOR: CLEAR

3. 89U UNIVERSAL MOUNTING BRACKET:

- A. MATERIAL: ABS, UL 94V-2

RJ-45	110 CONNECTOR	UNIVERSAL WIRING	
		T568B	T568A
5	1	WHITE/BLUE	WHITE/BLUE
4	2	BLUE	BLUE
1	3	WHITE/ORANGE	WHITE/GREEN
2	4	ORANGE	GREEN
3	5	WHITE/GREEN	WHITE/ORANGE
6	6	GREEN	ORANGE
7	7	WHITE/BROWN	WHITE/BROWN
8	8	BROWN	BROWN

CATEGORY 6 CONNECTING HARDWARE REQUIREMENTS												
FREQUENCY (MHz)	1.0	4.0	8.0	10.0	16.0	20.0	25.0	31.25	62.5	100	200	250
NEXT LOSS (db)	75.0	75.0	75.0	74.0	69.9	68.0	66.0	64.1	58.1	54.0	48.0	46.0
FEXT LOSS (db)	75.0	71.1	65.0	63.1	59.0	57.1	55.1	53.2	47.2	43.1	37.1	35.1
RETURN LOSS (db)	30.0	30.0	30.0	30.0	30.0	30.0	30.0	30.0	28.1	24.0	18.0	16.0
INSERTION LOSS(db)	0.10	0.10	0.10	0.10	0.10	0.10	0.10	0.11	0.16	0.20	0.28	0.32

<b>PATCH PANEL, VERTICAL, CAT 6, 12-PORT</b>		 PremiumProducts ProvenPerformance CompetitivePrices	
ITEM NO.	ICMPP12V60		REV. B
DWG NO.	PSMPP12V60		PAGE NO. 2